

FLOWCON

Flow sensor



EN

02

Operation & Maintenance Instructions

Read these operation and maintenance instructions before start up!

To be held for future reference.

Contents

| | |
|---|-----------|
| 1. Safety advice | 3 |
| 1.1 General..... | 3 |
| 1.2 Instruction symbols used in the operating manual | 3 |
| 1.3 Qualification and training of personnel | 3 |
| 1.4 Important safety instructions | 4 |
| 1.5 Hazards due to non-compliance with safety instructions | 4 |
| 1.6 Safe operation..... | 4 |
| 1.7 Safety instructions for the owner/operator | 4 |
| 1.8 Unauthorised modifications and production of spare parts..... | 4 |
| 1.9 Metering of chemicals | 5 |
| 1.10 Scope of delivery..... | 5 |
| 2. Function | 6 |
| 2.1 Evaluation unit FLOWCON..... | 6 |
| 3. Dimensions | 7 |
| 4. Technical data..... | 10 |
| 4.1 Flow Sensor FLOWCON | 10 |
| 4.2 Electronic Evaluation Unit FLOWCON | 10 |
| 4.3 FLOWCON part numbers..... | 11 |
| 4.4 Selection guide | 11 |
| 5. Installation | 12 |
| 5.1 General..... | 12 |
| 5.2 Installation location..... | 13 |
| 6. Start-up | 14 |
| 6.1 Wartung..... | 15 |
| 7. Control panel of the electronic evaluation unit | 16 |
| 8. Wiring..... | 16 |
| 8.1 Wiring for control by external contacts | 17 |
| 8.2 Wiring for internal or analog controlled solenoid pump | 17 |
| 8.3 Wiring for internal or analog controlled motor pump..... | 17 |
| 8.4 Setting of maximum stroke frequency at DIP switch..... | 17 |
| 8.5 Setting of allowable faulty strokes | 18 |
| 9. Spare parts list FLOWCON | 18 |
| 10. Warranty..... | 19 |

1. Safety advice

1.1 General

This operating manual contains basic information to be adhered to during installation, operation and maintenance. It is therefore essential that the fitter as well as the relevant qualified staff/operator read the operating manual before installing and starting up. It must be accessible at the dosing pump/system at all times.

Not only must the general safety instructions under this main heading of Safety be observed, but also the specific safety instructions outlined under the other headings.

1.2 Instruction symbols used in the operating manual

If the safety instructions in this operating manual are not adhered to it may endanger people, the environment and the dosing pump/system. These instructions are denoted by the following symbols:

DANGER!

Refers to an imminent danger. Non-compliance can lead to death or serious injury.



WARNING!

Refers to a potentially dangerous situation. Non-compliance can lead to death or serious injury.



CAUTION!

Refers to a potentially dangerous situation. Non-compliance can lead to minor injury or damage to property.



NOTICE! or INFORMATION!

Are safety instructions which if ignored can lead to danger to the machine and its functions.



IMPORTANT!

This is additional information to ensure that work is facilitated and a trouble-free operation.



There are marking affixed directly onto the device, e.g.:

- specification label
- warning notices

that must be observed without fail and remain fully legible at all times.

1.3 Qualification and training of personnel

The personnel employed for the installation, operation, inspection and maintenance work must be qualified to do so. The user has to define precisely the areas of responsibility, competence and supervision of the personnel. If the personnel do not have the necessary knowledge, they must be trained and instructed. If necessary, the manufacturer/supplier

may do this on behalf of the pump's owner. Furthermore, the owner of the system has to ensure that the contents of this operating manual is fully understood by the personnel.

1.4 Important safety instructions

When installing and using this electrical equipment, basic safety precautions should always be followed, including the following:

READ AND FOLLOW ALL INSTRUCTIONS!



WARNING!

To reduce the risk of injury, children are not permitted to use this product, they should be closely supervised at all times.



WARNING!

To reduce the risk of an electric shock, replace a damaged cable immediately.



WARNING!

To reduce the risk of an electric shock, do not connect the unit to an extension cord with electric voltage, use a suitably located socket instead.

SAVE THESE INSTRUCTIONS!

1.5 Hazards due to non-compliance with safety instructions

Failure to comply with safety instructions may endanger not only people, but also the environment and the dosing pump/system. Non-compliance with the safety instructions can lead to the loss of all claims for damages. Non-compliance can lead to the following hazards:

- Malfunction of the dosing pump/system's important functions.
- Malfunction of prescribed methods of maintenance and servicing.
- Endangering people through electrical, mechanical and chemical causes.
- Endangering the environment due to leakages of hazardous substances.

1.6 Safe operation

The safety instructions in this operating manual have to be observed. The owner is responsible for ensuring compliance with local safety regulations.

1.7 Safety instructions for the owner/operator

Leakages (e.g. due to ruptures in the hose) of hazardous materials conveyed (e.g. abrasive, toxic) have to be discharged in such a way so that there is no danger to people and the environment. Statutory regulations must be observed.

1.8 Unauthorised modifications and production of spare parts

Modifications and alterations are only permitted after consulting with the manufacturer. Genuine spare parts and accessories authorised by the manufacturer ensure security.

IMPORTANT!

The use of spare parts that are not genuine negates all claims for damages.

**1.9 Metering of chemicals****CAUTION!**

When working on batchers the accident prevention regulations applicable on-site must be observed and the prescribed personal protective clothing must be worn. This operating manual contains basic information to be adhered to during installation, operation and maintenance. It is therefore essential that the fitter as well as the relevant qualified staff/operator read the operating manual before installing and starting up. It must be accessible at the dosing pump/system at all times.



Not only must the general safety instructions under this main heading of Safety be observed, but also the specific safety instructions outlined under the other headings.

CAUTION!

Chemical could spray out. This may lead to caustic or other burns. Always relieve the system/pump pressure before starting work on the dosing pump.

**WARNING!**

Never look into the open end of a clogged line or valve. Chemical may emerge unexpectedly and cause caustic or other burns to face and hands. Before start up, all connections must be inspected for correct tightness and, if necessary, must be further tightened using appropriate tools.

**1.10 Scope of delivery****IMPORTANT!**

Please unpack the hose pump and ordered accessories attached with great care, so that small parts do not remain unnoticed in the packaging. Please compare the scope of delivery immediately with the delivery note. The reason for any discrepancies has to be ascertained.



2. Function

FLOWCON is a flow monitoring system comprised of several components specifically designed for pulsating flows associated with positive displacement solenoid or motor-driven dosing pumps. Its function is based on the evaluation of pulsations occurring typically in the discharged volume flow of dosing pumps. During the discharge stroke a float element is lifted by the pulsating liquid and thus operates a reed contact. By setting a switch point, the flow rate determined previously by gauging is monitored. Thus the sensor is not only sensing, whether the pump is operating, but also whether the preset flow rate is maintained. Provided that system pressure and fluid viscosity are constant, the repeatability is 10-20%.

A bypass valve allows for the monitoring of a dosing range of 0.05...12 l/h for solenoid-driven dosing pumps and 1...50 l/h for motor-driven dosing pumps.

The electronic evaluation can be carried out by an on-site PLC, a meter or an electronic unit, specifically developed for this purpose.

2.1 Evaluation unit FLOWCON

The evaluation unit FLOWCON allows for the monitoring of a dosing pump's discharge volume in an electronic way. Failure or incorrect operation of the dosing pump is indicated by means of a relay contact.

Monitoring of solenoid-driven dosing pumps

A stroke sensor attached to the pump (refer to MB 1 32 01) registers, when the dosing pump has carried out a discharge stroke. In the case of accurate dosing this discharge stroke is confirmed by the reed contact of the FLOWCON flow sensor. As the stroke sensor senses the stray field of the drive solenoid, it does not matter whether the pump is controlled internally or externally.

If the pump is triggered by controller or water meter contacts only, it is also possible to compare the pump control signal with the acknowledgement of the FLOWCON flow sensor.

Monitoring of motor-driven dosing pumps

In the case of motor-driven pumps, the contact of a proximity initiator at the drive eccentric is compared with the contact of the FLOWCON flow sensor.

The proximity sensor can be omitted if the pump is controlled by external contacts.

The evaluation unit can be set to accept a tolerable number (max. 7) of faulty strokes. Only after exceeding this number of faulty strokes, an alarm (relay contact) is released.

If the defined number of acceptable faulty strokes is not reached within 128 discharge strokes, the faulty strokes indicated so far will be cleared. Thus an unnecessary failure indication is avoided (i.e. 1 faulty stroke / 128 discharge strokes = 0,78% dosing error rate).

3. Dimensions

FLOWCON

| G | L |
|-------|-----|
| G 5/8 | 152 |
| G 3/4 | 154 |

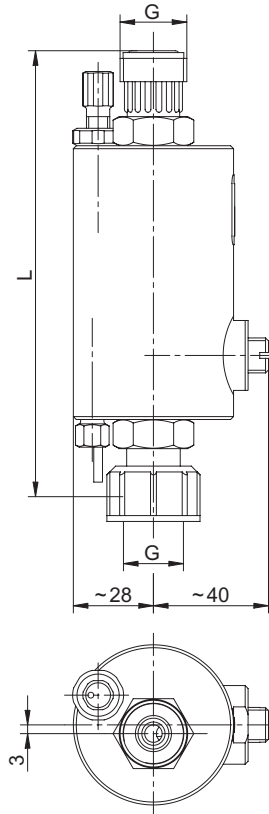

Base mount

| G | i/a | A |
|-------|------|----|
| G 5/8 | 4/6 | 45 |
| | 6/12 | 58 |
| G 3/4 | 6/12 | 58 |

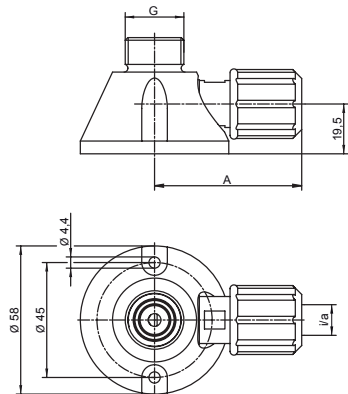

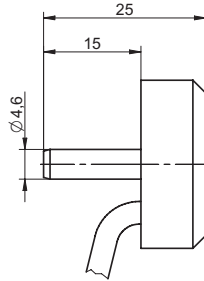
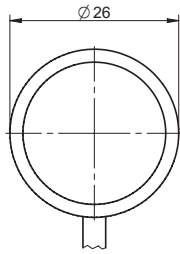

Stroke Sensor HR-K

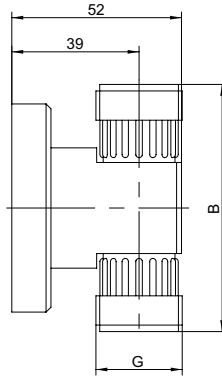
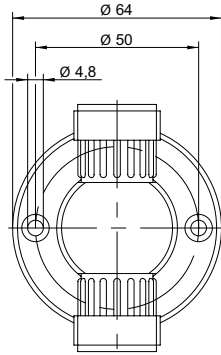

Wall mount

| G | B |
|-------|----|
| G 5/8 | 72 |
| G 3/4 | 76 |

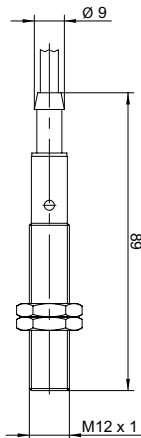

Stroke Sensor

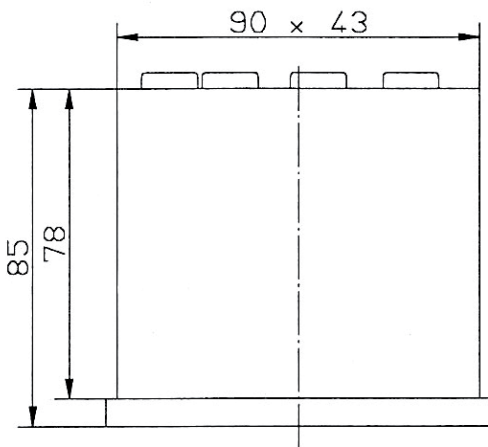
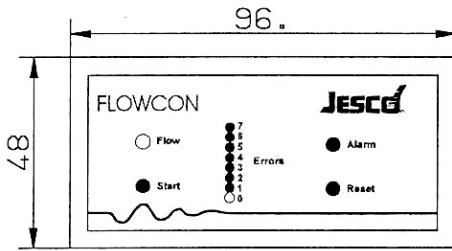

Electronic Evaluation Unit
panel mount

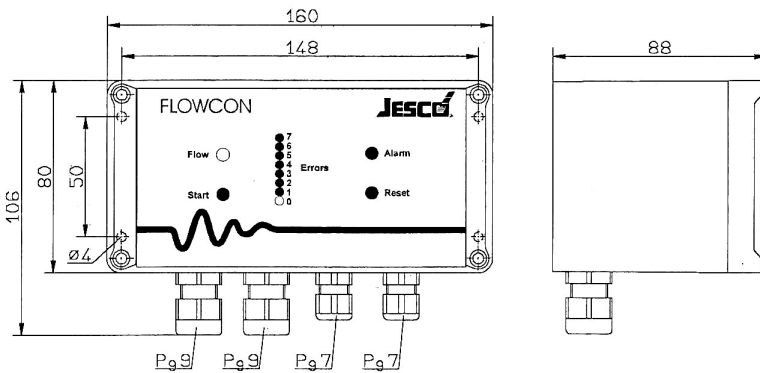

Electronic Evaluation Unit
wall mount

4. Technical data

4.1 Flow Sensor FLOWCON

| | |
|--|--|
| Housing material | PVC and PMMA |
| Sealing material | FPM or EPDM |
| Connections | Inlet: Union nut G 5/8 or G 3/4 Outlet: G 5/8 or G 3/4 spigot |
| Dosing range | Solenoid-driven dosing pump 0.05...12 l/h (Not applicable for MAGDOS LT 17.) Motor-driven dosing pump 0.5...50 l/h |
| Max. system pressure | 10 bar |
| Max. viscosity at stroke frequency 100/min | 20 mPa·s (20 cps) |
| Max. viscosity at stroke frequency 150/min | 10 mPa·s (10 cps) |
| Max. temperature of process fluid | 35 °C (95 °F) |
| Switching capacity of reed contact | 48 VAC/DC, 0.5 A, max. 12 VA |

4.2 Electronic Evaluation Unit FLOWCON

| | |
|--------------------------------|---|
| Mounting | Wall mount IP65 or Panel mount |
| Electrical data | 230 VAC, 1 Ph, 50/60 Hz, 5VA 115 VAC, 1 Ph, 50/60 Hz, 5VA |
| Alarm relay switching capacity | 230 VAC or 110VAC, 4 A 1-pole switch, normally open at alarm |

Display

| |
|--|
| 1 red LED (Start) blinks short on triggering of a stroke. Blinks long on a faulty stroke. |
| 1 green LED (Flow) blinks on every stroke that is verified by the stroke sensor. |
| 1 green LED (0) is ON as long as there is no faulty stroke. |
| 7 green LED's (Error) indicate faulty strokes by turning red. |
| 1 red LED (Alarm) lights when the number of allowable faulty strokes is exceeded (alarm output relay switches). |

4.3 FLOWCON part numbers

Flow Sensor FLOWCON:

| | /FPM | /EPDM |
|-------------|----------|----------|
| G 5/8, PVC | 13300302 | 13300402 |
| G 3/4, PVC | 13300304 | 13300404 |
| G 5/8, PMMA | 13338132 | 13300202 |
| G 3/4, PMMA | 13338134 | 13300204 |

Electronic Evaluation Unit FLOWCON:

| | wall mount | panel mount |
|---------------------|------------|-------------|
| 230 VAC, | 13300100 | 13300102 |
| 115 VAC, wall mount | 13300101 | 13300103 |

| | |
|----------------------|----------|
| Stroke Sensor HR - K | 13234247 |
| Stroke Sensor | 78008 |

Base Mount PVC:

| | |
|-------------------------------|-------|
| G 5/8, 4/6 tubing connection | 34560 |
| G 5/8, 6/12 tubing connection | 34561 |
| G 3/4, 6/12 tubing connection | 34562 |

Tubing connections PVC:

| | |
|--------------|-------|
| G 5/8 - 4/6 | 20975 |
| G 5/8 - 6/12 | 19180 |
| G 3/4 - 6/12 | 19175 |

Wall Mount PVC:

| | |
|-------|-------|
| G 5/8 | 34563 |
| G 3/4 | 34564 |

4.4 Selection guide

For complete monitoring of the pulsating flow the following equipment is required:

| | Solenoid-driven Dosing Pump | | Motor-driven Dosing Pump | |
|----------------------------|-----------------------------|-----------------|----------------------------|-----------------|
| | internal or analog control | contact control | internal or analog control | contact control |
| Flow Sensor | X | X | X | X |
| Electronic Evaluation Unit | X | X | X | X |
| Stroke Sensor HR-K | X | | | |
| Stroke Sensor | | | X | |
| Base Mount or Wall Mount | X | X | | |
| Tubing Connection | X | X | | |

5. Installation

5.1 General

Before installing FlowCon into a new or existing system, Lutz-Jesco recommends careful review of your system's design and plant layout. It is essential that all local rules, codes and regulations are followed in the design and installation of chemical feed equipment. It is also important that the system meets the technical demands required, such as flow rates and pressures. Many factors must be taken into consideration, including process fluid specifications, material compatibilities, chemical handling, electrical wiring, line losses and many more. With dosing pump systems particular attention must be paid to the piping system (i.e. length and diameter).

Both the system designer and the operator are responsible for ensuring that the entire plant is constructed to prevent damage to plant equipment or building resulting from leakage or technical failure. In case the chemical system holds a high hazardous potential, it has to be designed in a way that during a technical failure no unreasonable damage occurs. Therefore we recommend the installation of leakage monitoring devices and containment trays.

For safe long-term operation a regular visual control is necessary. Regular maintenance can prevent unscheduled shutdowns and failures. Proper installation allows sufficient room for operators and maintenance personnel to access each component for adjustment and servicing.

If plastic parts are installed (i.e. connections), suitable tools have to be used. The mounting must be done with the appropriate torque in order to avoid damage.

Plastic parts (in particular PVC parts) can be tightened easier and loosened again, when the threads have been lubricated (i.e. with silicone grease).



NOTE!

NOTICE!

The compatibility of the lubricant with the process fluid is to be verified!

5.2 Installation location

The flow sensor FLOWCON can be mounted directly onto the discharge valve of a motor-driven pump. With solenoid-driven dosing pumps the direct mounting onto the discharge valve is not permitted, since disturbances may be generated by the stray field of the drive solenoid. A minimum distance of 20 cm is always to be kept between the FLOWCON and the dosing pump. Ferrous objects like tools could likewise affect the function. Therefore a minimum distance of 10 cm should be maintained. The flow sensor must always be mounted in a straight vertical position. Since the pulsating discharge of the dosing pump is being evaluated, pulse dampening due to orifices or pulsation dampeners must be avoided. Therefore the use of tubing longer than 1 m should be avoided therefore

IMPORTANT!

At the application of a hose it has to be paid attention to that no loops occur between dosing pump and FLOWCON! Due to their effect, developing air and gas pockets can impair the function of the FLOWCON.



IMPORTANT!

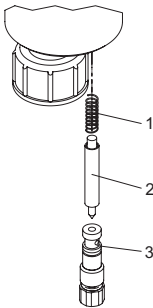

The float (2) inside the FLOWCON sensor is spring-loaded from design.

NOTICE!

When thin media (up to 20 mPas / 20 cps) is metered in very small portions the spring should be removed.

ATTENTION!

Especially with the application of the Minidos A3 and Minidos A5 must the spring be removed in any case!

ATTENTION!

The orifice screw (3) is to be tightened by hand only! Tools must not be used!



NOTE!



ATTENTION!



ATTENTION!

6. Start-up

If the electronic evaluation unit FLOWCON is used for monitoring, the dosing pump's maximum stroke frequency and the number of the permissible false strokes has to be set at start-up (refer to section 8. Electrical connection)

Venting:

1. Bypass valve (1) completely open (turn spindle counterclockwise)
2. Switch on pump and let it operate until air bubbles are no longer present.

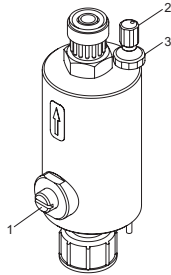

Setting of the switch point with opener (with monitoring by electronic evaluation unit FLOWCON):

1. Switch off pump and turn in contact screw (2) completely until reed contact closes (LED „Flow“ is off).
2. Turn out contact screw (2) again by three rotations (LED „Flow“ is on)
3. Switch on pump and close bypass valve (1) slowly until LED „Flow“ is off during each dosing stroke. To ensure a complete venting of the float channel, let the pump operate for a few minutes until air bubbles are no longer present. If the LED does not blink with the bypass valve completely closed, turn in contact screw slightly.
4. Turn in contact screw (2) slowly until LED just stops blinking (and illuminates continuously).
5. Turn out contact screw again by 1/2 or 3/4 revolution and tighten lock nut (3) (LED blinks).
6. To check the switch point, reduce stroke length of the pump by approx. 10-20 % (LED does not blink anymore).

Setting of switch point with closer (with external electronic evaluation it is possible to apply a closing contact)

1. Switch off pump and completely turn in contact screw (2) until reed contact closes (LED "Flow" shows green).
2. Turn out contact screw (2) again by three rotations (LED "Flow" off)
3. Switch on pump and close bypass valve (1) slowly until LED "Flow" blinks during each dosing stroke. To ensure a complete venting of the float channel, let the pump operate for a few minutes until air bubbles are no longer present. If the LED does not blink with the bypass valve completely closed, turn in contact screw slightly.
4. Turn out contact screw (2) slowly until LED just stops blinking.
5. Turn in contact screw again by 1/2 or 3/4 revolution and tighten lock nut (3) (LED blinks).
6. To check the switch point, reduce stroke length of the pump by approx. 10-20% (LED does not blink anymore).

The switch point is thus set so that the flow rate of the pump can be monitored. If the number of tolerable faulty strokes is exceeded due to a malfunction of the dosing pump, the alarm relay of the electronic evaluation unit switches and the „Alarm“ LED shows red. After error elimination the Reset key must be operated.

IMPORTANT!

If a reliable adjustment of the switch point is not possible, it is recommended to remove the spring above the float element / from the float channel (refer to section 2. Installation)



IMPORTANT!

6.1 Maintenance

The FLOWCON is self-monitoring. This means, if for example there is a blockage in the medium wetted bore an alarm will be triggered because the reed contact is not being activated.

A leakage inspection concerning the connections and pipes is regularly, preferably half yearly, to undertake. Especially when dosing aggressive chemicals or chemicals which make the floater adhere to the bore, it is recommended to shorten the inspection intervals.

Please note: when taking the FLOWCON apart it is important that all pressurised lines are relieved of their pressure. (also see chapter 1 safety instructions)

7. Control panel of the electronic evaluation unit

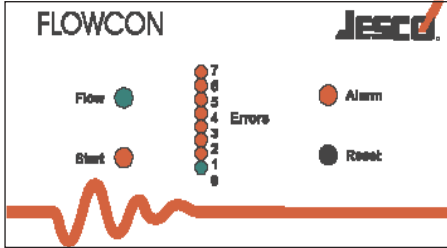

| | |
|-------|--|
| Start | On triggering of a stroke, the LED is read and the blinking sequence is short. A faulty stroke is indicated by a long blinking sequence. |
| Flow | The LED is green and blinks on every stroke that is verified by the stroke sensor. |
| Error | When there are no faulty strokes, the LED (0) is green. Red LED's (1...7) turn red to indicate each faulty stroke. |
| Alarm | LED is red when the number of allowable faulty strokes is exceeded (alarm output relay switches). |
| Reset | Press this touchpad to clear the alarm and the accumulated faulty stroke errors. |

8. Wiring

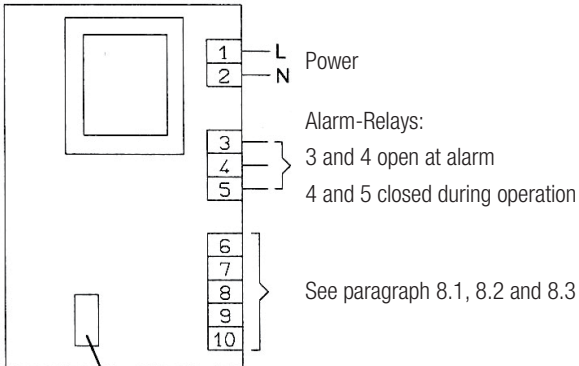

DIP-switches for configuration of max. stroke frequency (see paragraph 8.4) and of allowable faulty strokes (see paragraph 8.5).

8.1 Wiring for control by external contacts

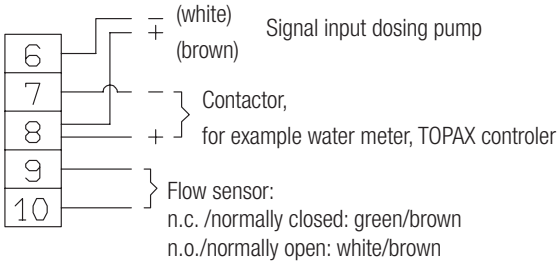

8.2 Wiring for internal or analog controlled solenoid pump

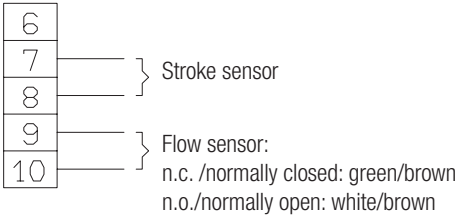

8.3 Wiring for internal or analog controlled motor pump

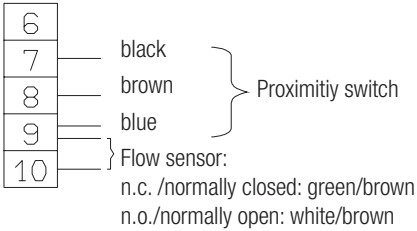

8.4 Setting of maximum stroke frequency at DIP switch

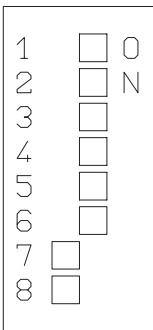

| Stroke frequency | Switch | |
|------------------|--------|-----|
| | 7 | 8 |
| up to 180/min | ON | ON |
| up to 120/min | OFF | ON |
| up to 90/min | ON | OFF |
| up to 65/min | OFF | OFF |

8.5 Setting of allowable faulty strokes

The setting of the allowable numbers of faulty strokes is done at switches 1...6 of the DIP switch.

Example:

| | |
|---------------------|--|
| Two faulty strokes | Switch 1 and 2 „ON“. Switch 3,4,5 and 6 „OFF“ |
| Four faulty strokes | Switch 1, 2, 3 and 4 „ON“. Switch 5 and 6 „OFF“ |



NOTE!

NOTICE!

If the defined number of allowable faulty strokes is not reached after 128 dosing strokes, the faulty strokes indicated so far will be cleared, thus a unnecessary failure indication can be avoided. (i.e. 1 faulty stroke / 128 discharge strokes = 0,78% dosing error rate).

9. Spare parts list FLOWCON

| | Part No. |
|----------------------------|----------|
| Gaskets, o-rings G5/8, FPM | 38200 |
| Gaskets, o-rings G3/4, FPM | 38201 |

Further spare parts

| | Part No. |
|---------------------------------------|----------|
| Reed contact complete (12) | 79233 |
| Float complete(7) | 34553 |
| Pressure spring (13) for reed contact | 34555 |
| Pressure spring (6) for float | 23788 |

*) included in set of gaskets and o-rings 38200/38201

CAUTION!

Please use exclusively original spare parts from the manufacturer, otherwise the warranty of the product will be lost.



ATTENTION!

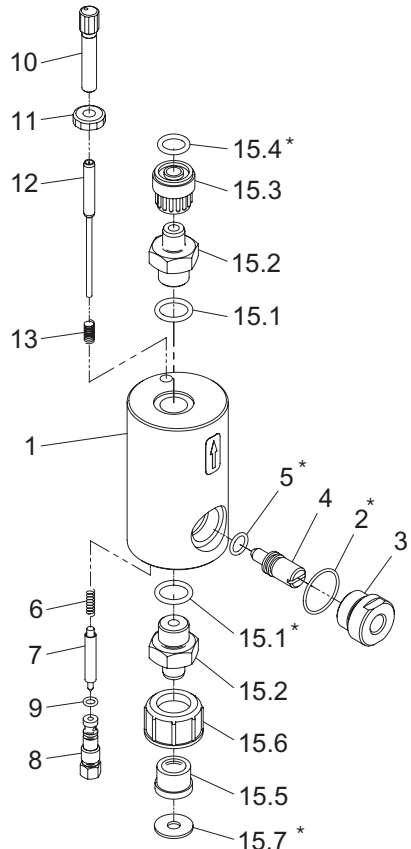

10. Warranty

Please copy and send with the device.

If the device breaks down within the period of warranty, please return it in a cleaned condition with the complete warranty application, filled out.

Sender

Company:..... Phone:..... Date:.....

Address:.....

Contact person:

Lutz-Jesco order-no.:..... Delivery date:.....

Device type:..... Serial no.:.....

Nominal capacity/nominal pressure:

Description of fault:

.....

.....

Type of fault:

1. Mechanical fault

- premature wear
- wear parts
- breakage/other damage
- damage in transit

3. Leaks

- connections
- dosing head

2. Electrical fault

- loose connections such as plug connector or cable
- operating elements (e.g.. switches/buttons)
- electronics - corrosion

4. No or inadequate suction

- defective diaphragm
- other

Service conditions of the dosing pump

Point of use / system designation:.....

Accessories used (Suction line, PDS, etc.):.....

.....

.....

Commissioning (date):.....

Duty period (approx. operating hours):.....

Please describe the specifics of the installation and provide a simple diagram with details of the material, diameter, length and levels.



Lutz-Jesco GmbH

Am Bostelberge 19
30900 Wedemark
Germany

Phone: +49 5130 5802-0
Fax: +49 5130 5802-68
E-Mail: info@lutz-jesco.de
Internet: www.lutz-jesco.de

24h-Hotline:
+49 5130 580 280

Austria

Lutz-Jesco GmbH

Aredstraße 29/212
2544 Leobersdorf
Austria

Phone: +43 2256 62180
Fax: +43 2256 6218062
E-Mail: info@lutz-jesco.at
Internet: www.lutz-jesco.at

Großbritannien

Lutz-Jesco (GB) Ltd.

Gateway Estate
West Midlands Freeport
Birmingham B26 3QD
Great Britain

Phone: +44 121 782 2662
Fax: +44 121 782 2680
E-Mail: info-gb@jesco.de
Internet: www.lutz-jesco.de

Niederlande

Lutz-Jesco Nederland B.V.

Nijverheidstraat 14 C
2984 AH Ridderkerk
Netherlands

Phone: +31 180 499460
Fax: +31 180 497516
E-Mail: info@lutz-jesco.nl
Internet: www.lutz-jesco.nl

Ungarn

Lutz-Jesco Üzetlég

Vasvári P. u. 9.
9024 Győr
Hungary

Phone: +36 96 523046
Fax: +36 96 523047
E-Mail: info-hu@lutz-jesco.hu
Internet: www.lutz-jesco.hu

USA

Lutz-JESCO America Corp.

55 Bermar Park
Rochester, NY 14624
USA

Phone: +1 585 426-0990
Fax: +1 585 426-4025
E-Mail: mail@jescoamerica.com
Internet: www.jescoamerica.com

East Asia

Lutz-Jesco
East Asia Sdn Bhd

Taman Perindustrian Jaya
47200 Petaling Jaya
Malaysia

Phone: +603 78454812
Fax: +603 78458413
E-Mail: info@lutz-jescoasia.com
Internet: www.lutz-jescoasia.com

Middle East

Lutz-Jesco Middle East FZE

P.O. Box 9614
SAIF-Free Zone Center
Sharjah
UAE

Phone: +971 6 5572205
Fax: +971 6 5572230
E-Mail: info-me@jesco.de
Internet: www.jescome.com



Best.-Nr. BA-Flowcon-02-V02
Subject to technical changes
© Lutz-Jesco GmbH 07.2007
Printed in Germany