

General

The advantage of diaphragm pumps compared to piston pumps is that they are operated without gland and leakage. Sudden diaphragm rupture is possible due to wear or inadmissible pressure peaks. To prevent further damage especially in the case of aggressive media, if the pump continued to work with the torn diaphragm, a control device is recommended. This leakage probe gives an alarm and causes the pump to stop as soon as leakage occurs.

Realization

The leakage probe can be connected easily to the PVC separation chamber (see MB 1 28 01) or the leakage tube of the standard diaphragm flange. Electrically the leakage probe is connected to a level relay (see drawing). If, due to a diaphragm rupture, the chemical gets in contact with the leakage probe, the level relay will switch. This make-and-break contact can be included in any pump control and/or it can be used for sending an alarm.

Upon alarm notification the diaphragm should be replaced. The leakage probe can be reused, after thorough cleaning and complete (the inside, too) drying.

Level Relay

The evaluation of the leakage is done with the help of a level relay. The wires coming out of the leakage probe are connected to the level relay (p/n 44300071 and 44300072). The level relay provides a no-load current (24V; 50/60Hz) toward the leakage probe. If the leakage probe is moistened by the chemical, the circuit is closed due to the chemical's conductivity and the level relay switches.

Sensitivity

If the level relay is controlled by the leakage probe, the conductivity of the liquid must be at least $10 \mu\text{S}/\text{cm}$. For well-conducting liquids, the level relay should be less sensitive as otherwise, malfunctions might occur. Maximum sensitivity is to be chosen for poorly conducting liquids. The sensitivity can be adjusted between 5kOhm and 100 kOhm.



Assembly

Remove leakage pipe and insert in leakage probe.
Note: If the leakage pipe is glued in, a tube can be used to connect the leakage probe.

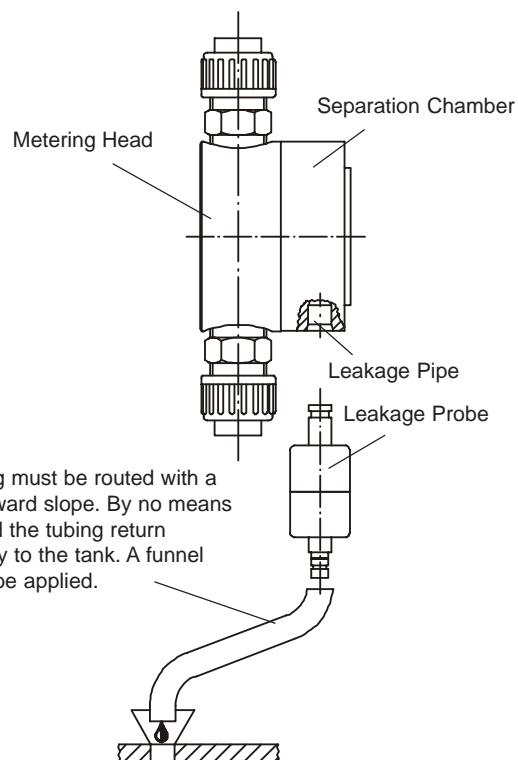

Dimensions

Depth with adapter plate +1.5mm

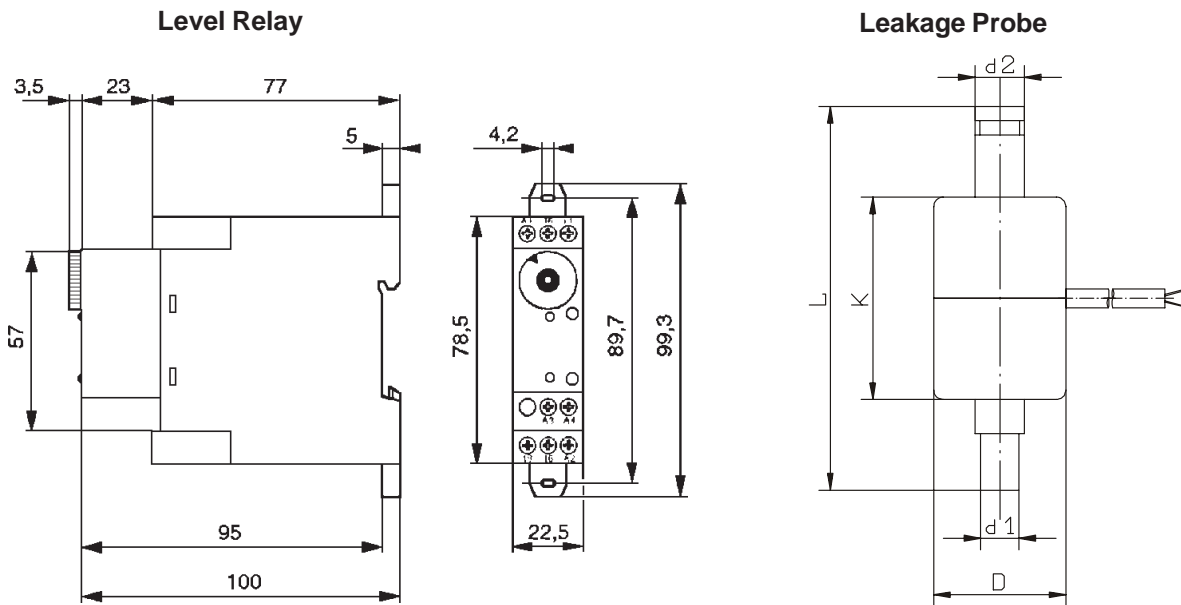

Leakage Probe

Leakage Probe for	d1	d2	D	K	L	Part-No.
Magdos E, EL, FL Magdos DE/DX 01 ... 20 Memdos E/DX 4 ... 76 Memdos TM 23, 45 Memdos M	10	8	28	43	81,5	13125200
Magdos DE/DX 40 ... 100 Memdos E/DX 110 ... 156 Memdos TM 110	16	16	40	46	93	13125204
Memdos E/DX 160 ... 380 Memdos ML Memdos MR	21	21	36	50	93,5	13125208

Wiring diagram

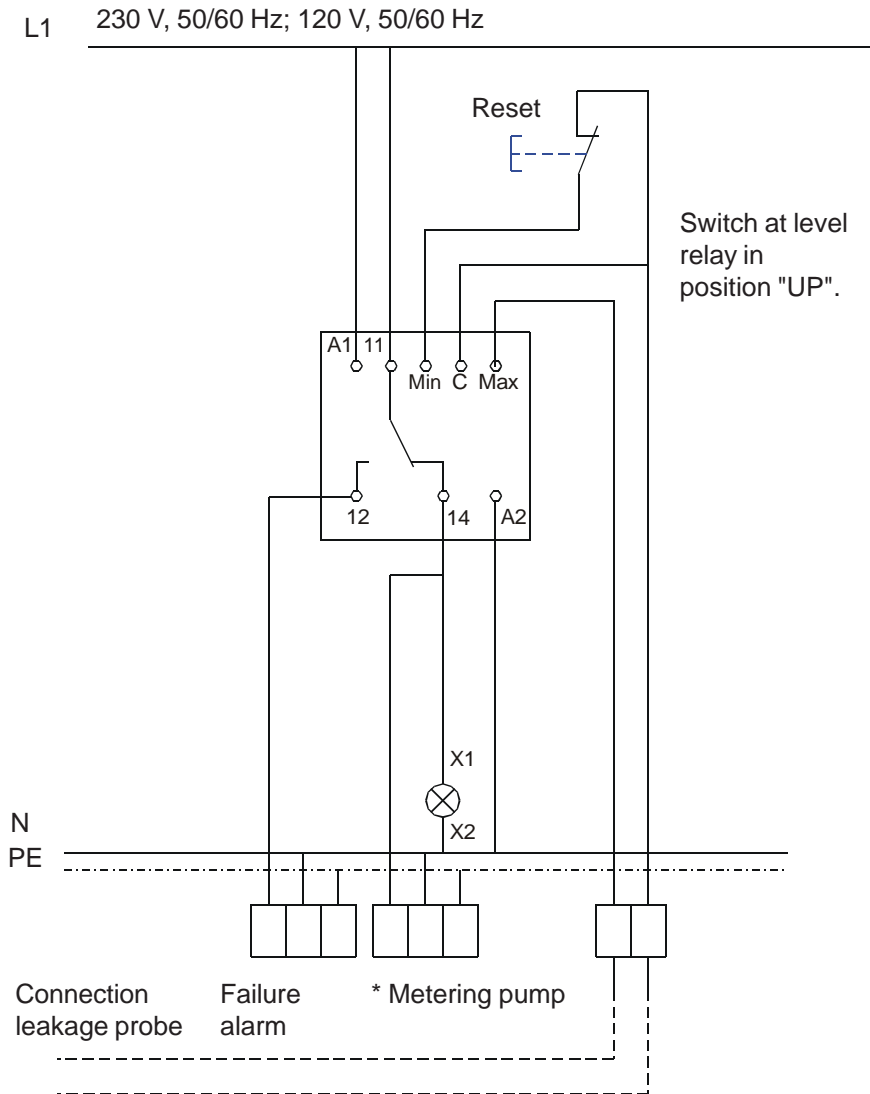

*Connection of solenoid-driven metering pump or of contactor for metering pump with 3-phase motor.

Technical data level relay

Dimensions

78x22.5x115mm
 Quick fastening for
 35 mm standard bearing rails acc. to DIN EN 50022
 Connection marking acc. to DIN EN 50005 Dimensioning
 of the striking and creeping distance according to VDE
 0110 Gr. C

Output Relay

Switching voltage: 230V, 50/60 Hz
 Switching power: max. 8A at 250V / 50 Hz
 Switching frequency: max. 7200/hour
 Mechanical life: 20x10⁶ switches
 Short-circuit strength: 10 A melting fuse

General

Connection voltage: 230V, 50/60 Hz; 120V, 50/60 Hz
 Special voltage upon request

Sensitivity of response: settable < 5 to < 100 kOhm

Operating temperature range: - 10 to + 55° C / 12° to 144° F

Part No.: 44300071 230V, 50/60 Hz
 44300072 120V, 50/60 Hz