

Constant suction pressure and leakage stop

The suction controllers **SDR 50 and SDR 500** have been developed because the flow rate of diaphragm metering pumps can be affected - among other factors - by a varying suction pressure or positive suction head. Metering pumps which are mounted above the tank (e.g. underground tanks) or also below the tank deliver less the more the tank gets empty, because either the suction lift increases or the positive suction head decreases.

Metering pumps with large diaphragms can develop a remarkable force on the stroke adjusting mechanism, if tank and density (e.g. sulphuric acid) are particularly high.

As a result of the mass moment of inertia in long suction lines overfeeding can occur when the diaphragm or the piston suddenly stops at the stroke limiting stop. Even if backpressure valves avoid overfeeding on the discharge side, a force is created at the stroke adjusting mechanism and on the suction side which increases wear.

In installations with a positive suction head towards the pump, the danger of leakage from the tank is given in the case of a diaphragm or line rupture.

Under normal conditions metering pumps must not be fed directly from pressure lines, because a pressure of e.g. 2 bar multiplied by the effective diaphragm area might exert destructive forces on the pump gear. On the other hand overfeeding would take place if a backpressure valve was not installed or wrongly adjusted on the discharge side.

In the case of long suction lines cavitation can result in reduced flow rates or the destruction of fittings due to the oscillating operation of metering pumps.

The aforementioned problems can be **solved** by one single fitting:

Suction Controller SDR 50 and SDR 500

The suction controller SDR is a spring-loaded diaphragm valve which is opened by the suction pressure of the metering pump. Thus it is ensured that no medium can flow if the pump is not working or cannot create a vacuum as a result of a line rupture.

Undesired suction at the pump outlet (e.g. siphoning effect) must be avoided by means of a backpressure valve.

Depending on the individual operating conditions, the required **maximum** vacuum can be set using an adjustable spring. For pumps with a positive suction



head, the vacuum to be set can be very low (approx. 50 mbar). This vacuum must be created by the pump in any case, even with a pressureless suction head. If the pump is installed below the tank only a fraction of the existing feed pressure must be produced as vacuum due to the different effective diameters of valve seat and diaphragm.

For emptying underground tanks or in the case of installations where the pump is located above the tank, the vacuum required for metering is set to the maximum vacuum occurring by means of the adjusting spring. The value corresponds to an almost empty tank. Thus the pump has to prime all the time as if the tank was empty and is hardly affected by the actual filling level or suction lift.

The flow in the suction line due to the mass moment of inertia will be stopped in the suction controller if the pump does not prime. In this case the suction controller must be installed close to the pump inlet in order to avoid shocks.

If the suction controller is also to be used as a leakage stop for the tank, it must be installed as close as possible to the tank in a mechanically protected position. In the case of line rupture, the suction controller closes immediately because of the spring force **and** the positive suction head effecting the locking element, since the pump cannot open the suction controller anymore due to the broken line.

If the suction controller is installed close to the pump, priming of the pump becomes easier because the volume below the controller diaphragm is immediately available at the pump when priming is started.

Caution! If the metering line between the pump and the process is under vacuum or tends to siphon because of the geodetic conditions, a backpressure valve must be installed at the end of the line.

Functional diagram SDR 500

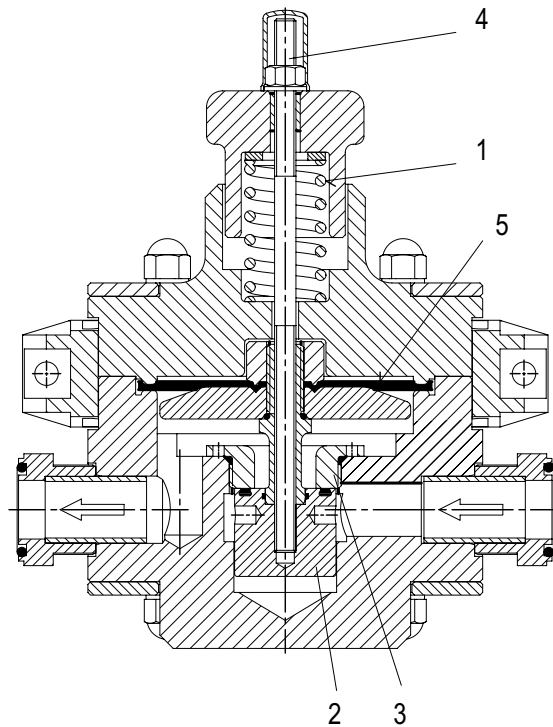

The liquid coming from right first faces a shut valve (valve head/valve seat 2+3) which is closed by the spring (1) and sealed additionally by the liquid pressure. Thus liquid can only flow if the valve head (2) is pushed down by the valve pin (4). This happens only after a vacuum has been produced at the left connection due to the suction stroke of the pump, causing the diaphragm (5) to move downwards and thus lift the valve head (2) off the valve seat (3).

Functional diagram SDR 50

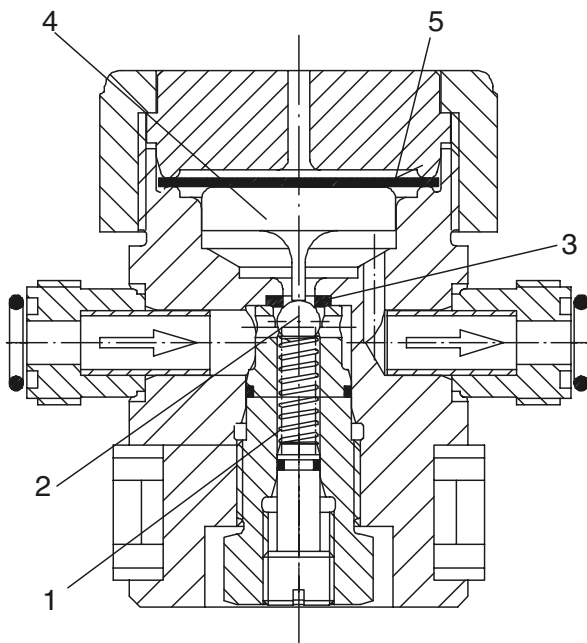

The liquid coming from left first faces a shut valve (ball/seat 2+3) which is closed by the spring (1) and sealed additionally by the liquid pressure. Thus liquid can only flow if the ball (2) is pushed down by the plunger (4). This happens only after a vacuum has been produced at the right connection due to the suction stroke of the pump, causing the diaphragm (5) to move downwards and press with the plunger (4) onto the ball (2).

Positive suction head

If the level of the supply tank is always higher than the pump, the spring force can be set to a low value which allows the ball to just touch the seat. The positive suction head seals additionally via the ball. Therefore atmospheric pressure can practically be found on the outlet side. Consequently, the pump must only create a vacuum which is strong enough to lift the ball from the seat. Due to the large diaphragm diameter compared to the seat diameter, a very low vacuum is required. The static pressure of the tank does thus not become effective in the pump head.

Negative suction head

If the level of the supply tank is always below the pump, the suction controller would continuously be open in the case of a pressureless spring because the atmospheric pressure would keep the ball open via the effective diaphragm area. To ensure a constant suction lift for the pump also in this case, the spring can be pressurized so that it always simulates the

maximum suction lift. The pump must then prime the maximum vacuum all the time no matter if the tank is almost full or empty. (Of, course, the pump must be able to overcome the highest suction lift at all; see technical data of the pump). To set the suction pressure precisely we recommend to install a pressure gauge between suction controller and pump (see MB 1 21 00 / 7).

Note: For easier dry priming set the suction pressure to minimum (spring released). Only after filling the suction line and the metering head should the maximum suction pressure be adjusted.

Installation

The installation location of the suction controllers depends on its task. Due to its low weight the **SDR 50** can be mounted freely in the case of rigid lines or fixed to the wall using pipe clamps. The **SDR 500** should be mounted by means of the supplied pipe clamp. The preferable installation position is horizontal, the diaphragm being located at the top (SDR 50 adjusting screw downwards, SDR 500 adjusting knob upwards). Thus it is ensured that the diaphragm is not damaged at an early stage due to deposits (especially in the case of suspensions).

Note: In the case of suspensions, not only the head of the metering pump should be rinsed but also the suction controller, in order to prevent failures. Frequency and duration depend on grain size and concentration of the suspension. If a pressure gauge is required the version with diaphragm pressure transmitter should be used by all means (see MB 1 21 00 / 7), because thus clogging of the pressure gauge pipe spring is impossible.

Examples of applications

Installation diagram for cases a to d

Legend

- 1 Tank or discharge line for medium to be metered
- 2 Shutoff valve
- 3 Suction controller **SDR**
- 4 Pressure gauge (optional)
- 5 Pulsation dampener (is recommended for **SDR 500**)
- 6 Metering pump
- 7 Backpressure valve, if there is the danger of siphoning

Note: In these examples of installation, except for the suction controller, no other fittings required or recommended are shown.

- a) Protection of the metering pump against excessive feed pressure due to high tanks or supply from discharge lines.

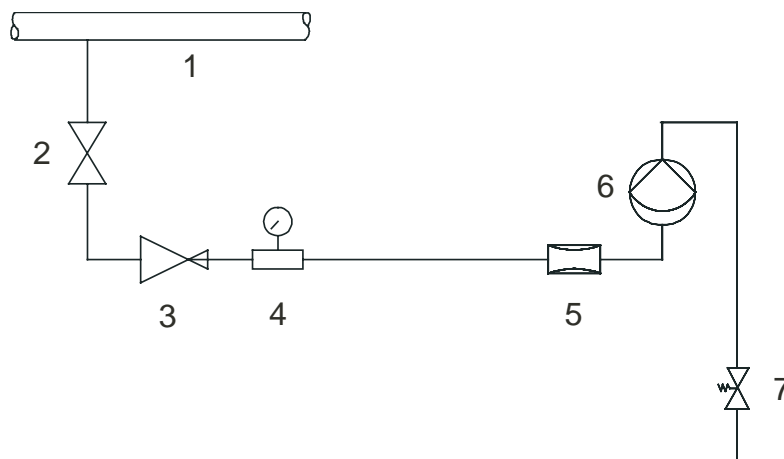

- b) Use as tank drain protection in the case of a diaphragm failure or line rupture and avoidance of siphoning

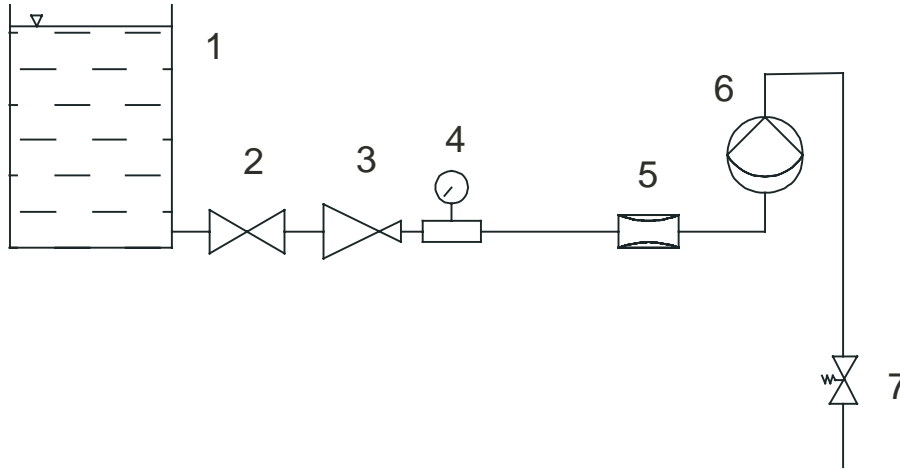

- c) Avoiding changing positive and negative suction heads which affect the metering accuracy.

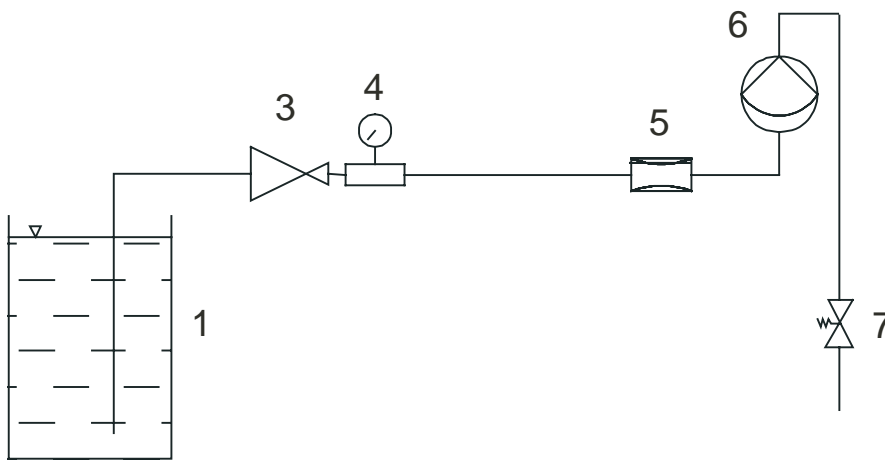

- d) Protection of the metering pump against pressure peaks due to acceleration in the case of long suction lines.

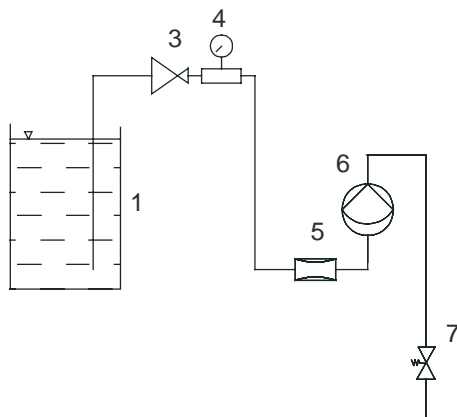

Dimensions SDR 50

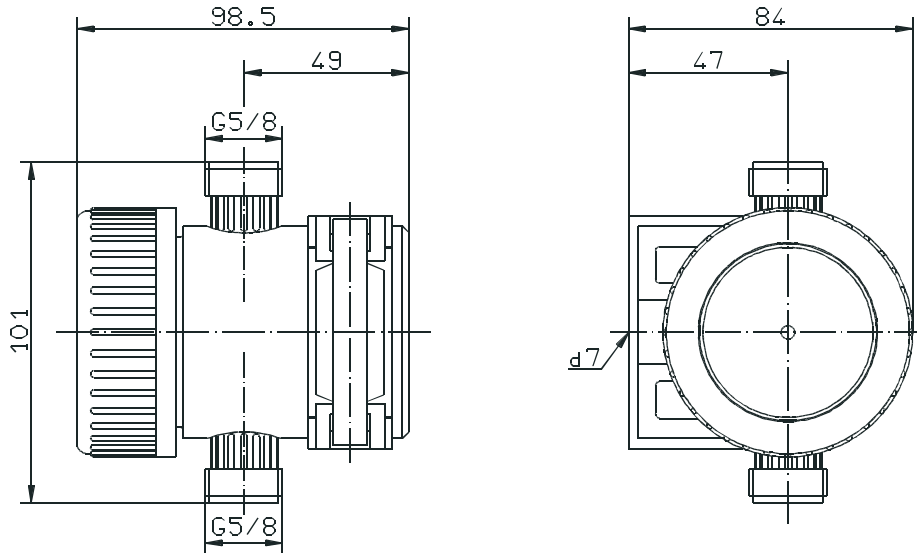

Connections

DN	Fig.	di	da	L	Part No. PVC
4	A	4	6	23	20975
6	A	6	8	30	25176
6	A	6	9	34	34925
6	A	6	12	51	19180
6	B	6	12	30	23092
6	C	-	10	15	23087
8	C	-	12	15	23089
6	D	-	G 1/4	20	23088

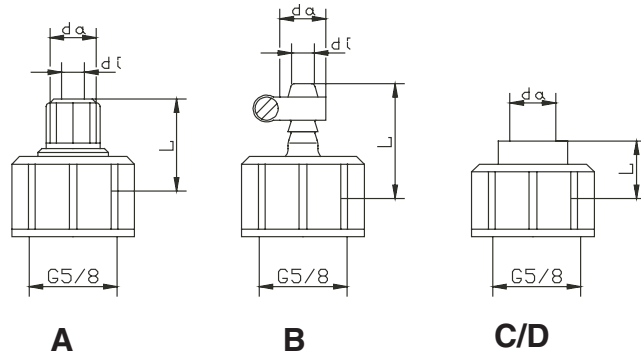

Technical data of suction controller SDR

		Part No.	
Technical data		12135072	12135135
Max. throughput		50 l/h	
Max. suction head		4 bar	
Max. suction pressure		300 mbar	
Max. temperature		40 °C	
Weight		0.5 kg	
Connection		G 5/8 a	
Material	Casing	PVC	
	Diaphragm	Viton	EPDM
	Seat	Viton	EPDM
	Ball	Glass	
	Spring	Hastelloy C	
	Adjusting screw	PVDF	

Dimensions SDR 500

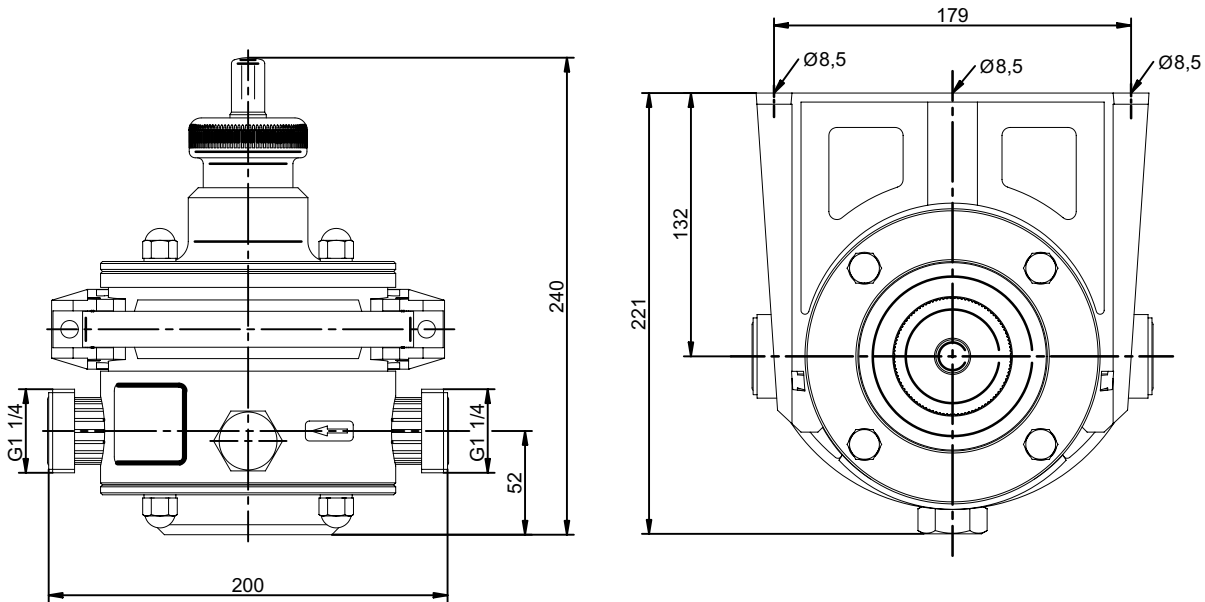

Connections

Fig.	d	L	Part No.
C	12	22	25923
	16	22	27672
	20	22	25937
D	G 3/8	28	25930
	G 1/2	22	25943
F	-	47	25956

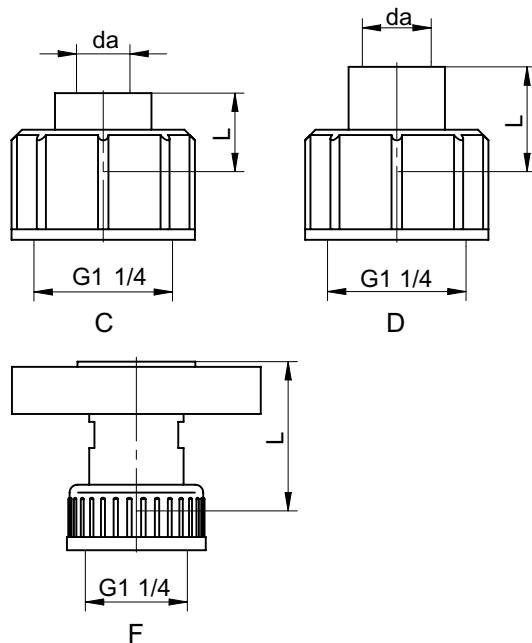

Technical data of suction controller SDR 500

		Part No.	
Technical data		12135409	12135425
Max. throughput		500 l/h	
Max. suction head		4 bar	
Max. suction pressure		600 mbar	
Max. temperature		40 °C	
Weight		3 kg	
Connection		G 1 1/4 a.	
Material	Casing	PVC	
	Diaphragm	Viton	Hypalon
	Sealing system	PVDF	

Accessories

to be mounted onto SDR 500 (optional)

Description	Part No.
Pressure gauge NG40, stainless steel, with glycerine dampening, assembly with PVC/Viton connecting parts	35482
Pressure gauge NG40, stainless steel, with glycerine dampening, assembly with PVC/EPDM connecting parts	35483

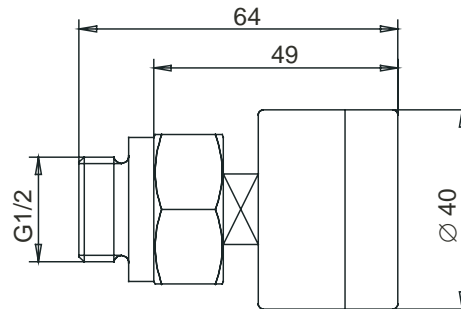

for SDR 50:

Description	Part No.
Pressure gauge assembly for SDR 50 with PVC pressure transmitter, diaphragm PTFE-coated, O-ring Viton	35485
Pressure gauge assembly for SDR 50 PVC pressure transmitter, diaphragm PTFE-loaded, O-ring EPDM	35486

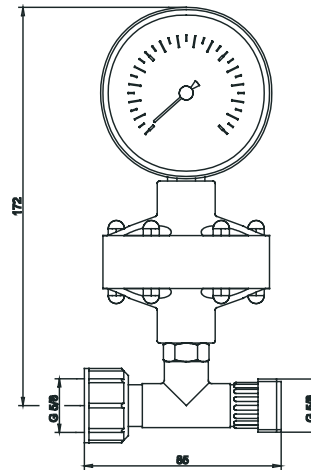

for SDR 500:

Description	Part No.
Pressure gauge assembly for SDR 500 with PVC pressure transmitter, diaphragm PTFE-coated, O-ring Viton	35481
Pressure gauge assembly for SDR 500 PVC pressure transmitter, diaphragm PTFE-loaded, O-ring EPDM	35487

