

General

In plant construction in general, and in water purification in particular, dry substances such as polyelectrolyte and activated carbon often have to be introduced into the water in fine suspension or dissolved in it.

Substances which are difficult to dissolve or wet can cause problems when introduced into the water, and can end up as lumps or simply layers on the surface of water. This results in an unacceptable reduction in the efficiency of the purification process.

The Suspensomat makes it possible to wet or pre-dissolve the dry substances simply, using the preparation water which is already to hand, in such a way that they are distributed homogeneously on introduction into the container. It is also recommended that an agitator be installed in the mixing chamber.

In the case of easily soluble substances such as calcium hydroxide or aluminium sulphate, only a simple **downcomer** without water rinsing as a dirt protector is necessary.

The Function of the Suspensomat

The Suspensomat is a cone, equipped with a number of tangentially directed, single stream nozzles on the upper edge, which form a rapidly rotating film of water over the entire surface of the cone. The injected dry substances therefore only falls in rotating water, which rotates more and more violently towards the outlet of the cone due to the acceleration, creating an intensive wetting effect.

A radiating head of nozzles situated at the base of the cone sprays the whole surface of the outlet of the cone concentrically with water. This brings about a second wetting, or a first for those particles which

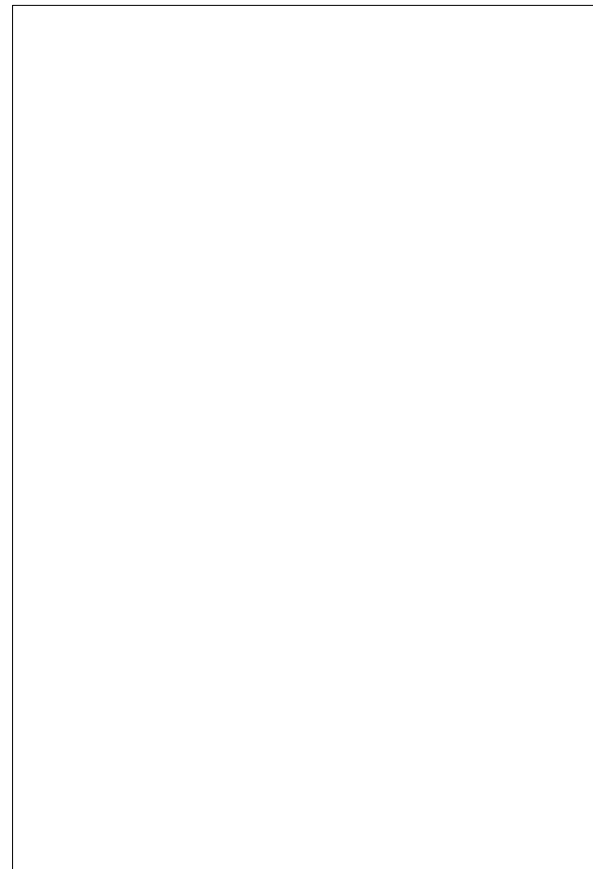

have fallen through the exact centre of the cone. The proportion of the quantity of water from the upper to the lower nozzle head can be adjusted at ball valves K1 and K2. The entire supply of water to the Suspensomat is carried out in bypass to the water which is already necessary to fill the mixing chamber. The entire quantity of water is provided by a dissolution water station with a variable area flow meter.

Technical data Suspensomat A

Max. quantity of water for both nozzle heads together: 1000 l/h.

Throughput quantity for dry substance: 500 l/h (e.g.: = 325 kg/h polyelectrolyte, 150 kg/h activated carbon).

Suspensomat B

Max. quantity of water for both nozzle heads together: 2500 l/h.

Throughput quantity for dry substance: 3000 l/h (e.g.: = 2000 kg/h polyelectrolyte, 900 kg/h activated carbon)

Fallrohr

Throughput quantity for dry substance: 3000 l/h (e.g.: = 1500 kg/h calcium hydroxide).

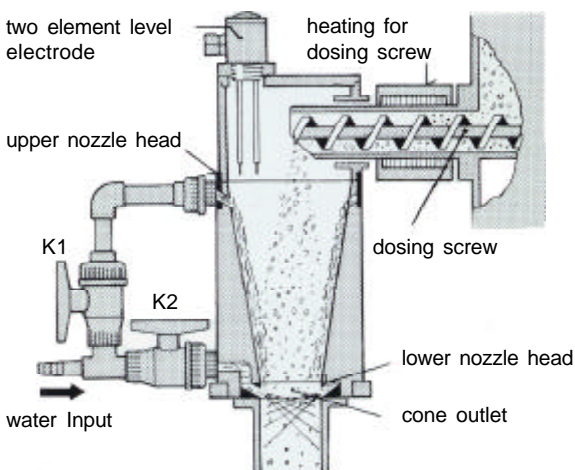

Accessories

1. A two element level electrode is available to ensure that the dissolution water does not overflow the funnel or flow into the dosing screw of the dry feeder due to blockage caused by large lumps. This electrode cuts off the water flow via the connected level relay at the solenoid valve, and switches off the dry feeder. For two element electrode and level relay see Dimension MB 4 10 01.

2. When suspending activated carbon it may be advisable to provide an additional wetting device, as activated carbon varies in its capacity for suspension. If desired, a water injector can be mounted directly under the Suspensomat. The strong action of this unit brings the water into particularly violent contact with the activated carbon. An injector may also be required when the mixture has to be put out a higher system pressure. Injectors have to be calculated according to individual operating data and are available on request.

Suspensomat Type A and B

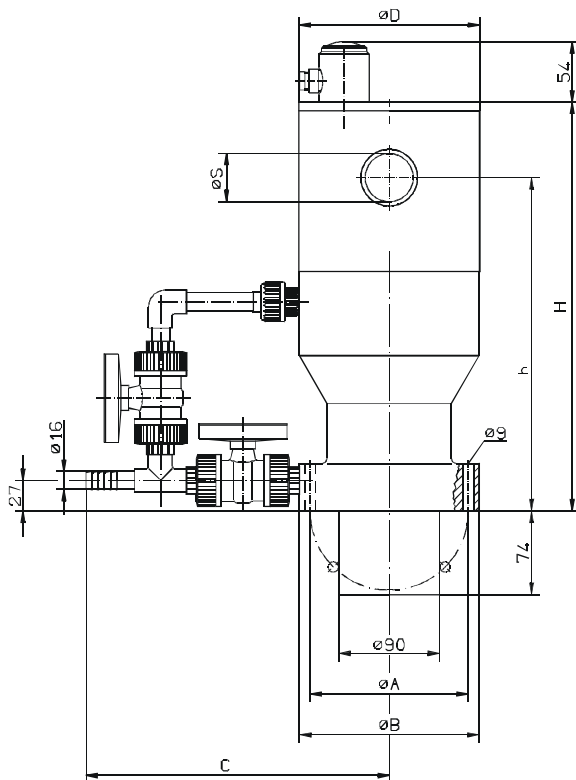

Downcomer

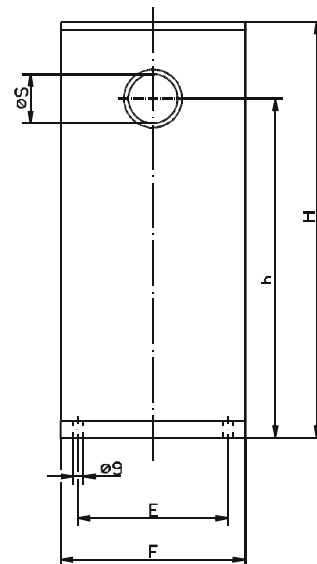

Dimensions and Part-No.

Dry feeder Type TEH	ø S	ø A	ø B	C	ø D	h	H	E	F	Suspensomat *		Down- comer
										Type A	Type B	
0004, 0014	43	140	160	270	160	295	362	130	160	31026830	-	31027082
0038, 0060, 0150	64	140	160	270	160	295	362	130	160	31026831	-	31027083
0320, 0420	77	140	160	270	160	295	362	130	160	31026832	-	31027084
0850, 1380	94	230	250	440	250	415	507	230	260	-	31026833	31027085
1900, 2650	120	230	250	440	250	415	507	230	260	-	31026834	31027086

* 2-rod-electrode is installed. Select relay from data sheet MB 4 10 01.